

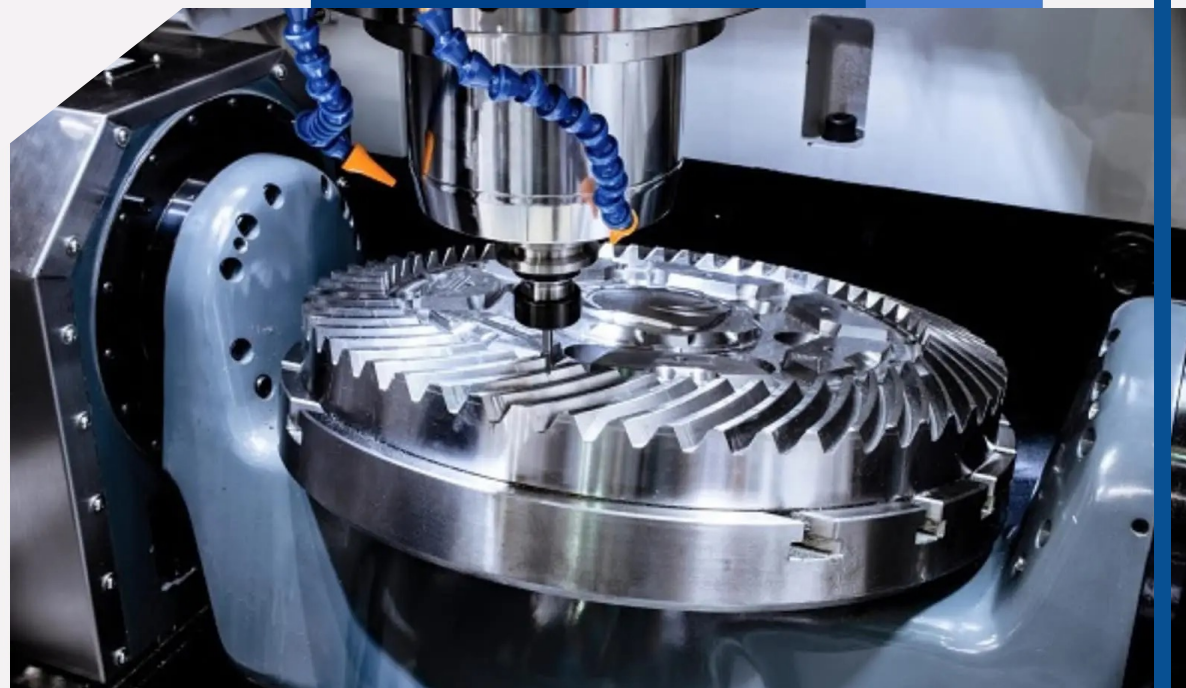

Corporate Dossier



Web:
lasermimar.com

Phone:
(+34) 916 572 874
(+34) 933 883 230

Mail:
comercial@jgautomotive.com



MIMAR

JG AUTOMOTIVE
Your partner in metal solutions



ABOUT US

LASER MIMAR is a company specialized in the **manufacturing** and **assembly of metal parts**, as well as **industrial boiler-making** and **sheet metal fabrication**. To carry out our projects, we rely on the most **advanced machinery and equipment**, operated by a highly skilled team of **professionals**.

Founded in **1999**, **LASER MIMAR** began its operations in **Parets del Vallès (Barcelona)** as a **metal industry manufacturer** focused on **sheet metal work** and **industrial boiler-making**, specializing in the production of **metal parts and assemblies** through processes such as **cutting, stamping, bending, punching, assembly, welding, and painting**.

Today, the company operates through fully **professionalized functional areas and services**, integrating the entire **production process** within its facilities.

In **2021**, **JG Automotive** acquired the **LASER MIMAR factory**, incorporating it into the **JG Automotive Group**.

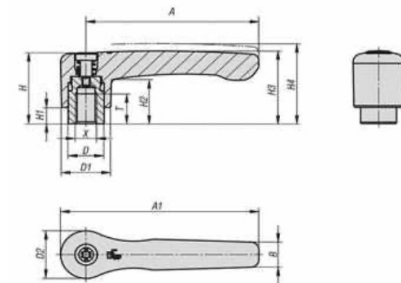

We manage the entire metal transformation and innovation process, providing expert engineering in project development.

LASER MIMAR

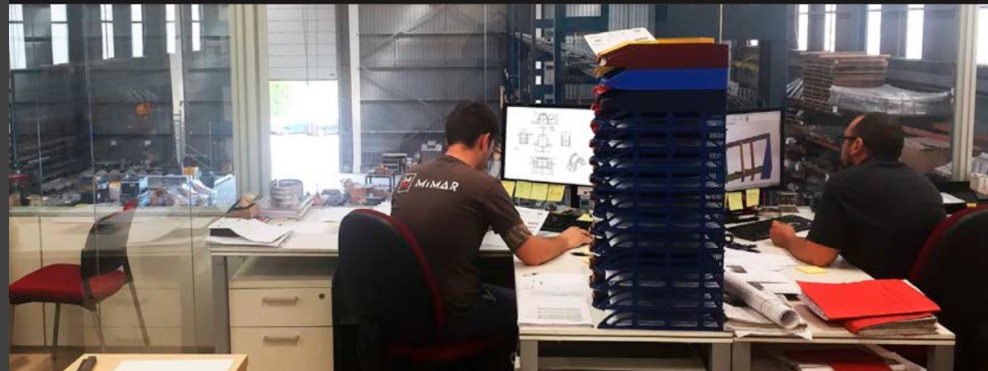

JG AUTOMOTIVE

JG Automotive was founded in **1982**, specializing in the **manufacturing, development, and supply of metal and mechanical components** for the **automotive and industrial sectors**.

In **2002**, together with 18 international partners, we founded **Global Alliance Automotive**, a group with over **230 engineers collaborating globally**. With manufacturing presence in **Brazil, Germany, China, India, Italy, Japan, South Korea, and the United States**, among others, the group achieves a combined **turnover of €1.72 billion**.

JG Automotive is a recognized leader as a **supplier and manufacturer of custom metal components**, producing parts for the **automotive and general industrial sectors** using the most **advanced technologies**, including **forging, casting, machining, stamping, turning, and sintering**.

Thanks to our expertise in these **manufacturing technologies**, we have successfully **diversified our industrial sectors** and continuously **optimized our production processes**.



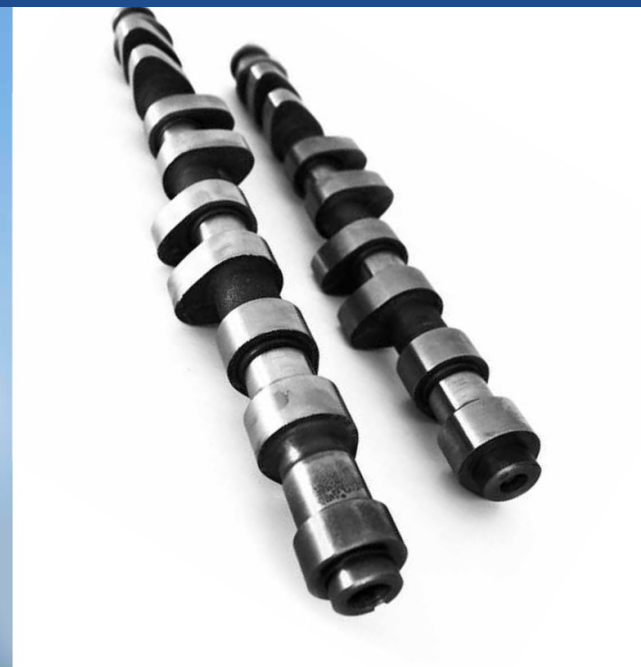

We are a leading supplier and manufacturer of custom metal components, producing parts for the automotive and general industrial sectors using the most cutting-edge technologies on the market.

— JG AUTOMOTIVE

JGA

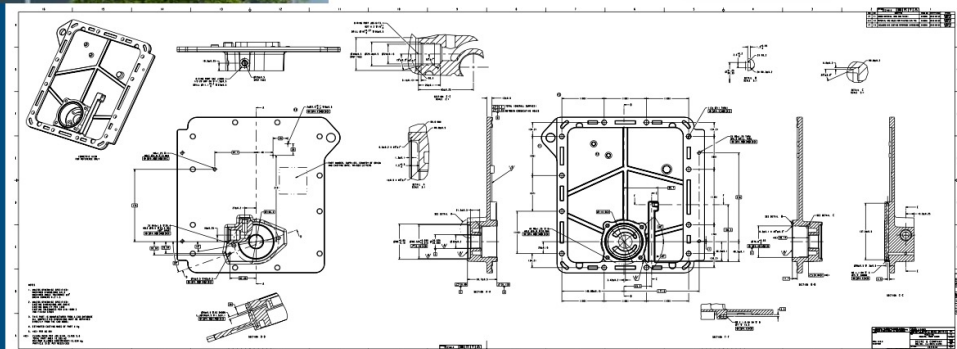

JG AUTOMOTIVE

Your partner in metal solutions

customers

AUTOMOTION

DIRECT CUSTOMERS



- Baires (Buenos Aires)
- Gestamp Navarra
- Edscha Automotive GmbH Hengersberg
- Bielefeld Unformtechnik GmbH.
- Cerveira Lda.
- Esmar
- Global Tooling S.L.
- Puebla Sa De Cv
- Vendas Novas Unipessoal



- Alcasting
- Goiaín
- Forjas Minas
- Gameko
- Mar Sk Ro
- Mecauto
- Vilanova
- Nova Recid
- Recitec
- Zdanice
- Egaña



- Kober
- SAS
- Paderborn



- Polska
- SaDeCv



- ITW Mikalor
- ITW Global Fastener España
- ITW Shakeproof
- ITW Rivex



- ZF Friedrichshafen AG
- ZF Hungaária KFT
- ZF Boutheaón S.A.S
- ZF do Brasil
- ZF Kama



- Altan Plastik
- Aptiv
- Irfan Plastik
- OcakKalip



- Pontedera



- JD Germany
- JD USA
- JD Spain

INDIRECT CUSTOMERS



- Adient | Alagon
- Adient | Calatorap



- Kayaba Suspensions Europe



- Sekurit Spain
- Sekurit Portugal



JG AUTOMOTIVE

Your partner in metal solutions

customers

AUTOMOTION

DIRECT CUSTOMERS

• **APTIV** •

 **OFFICINE VICA**

Groupe
defta 

TRISTONE

DEUTZ®

- Grupo Riza
- ABC Plásticos
- Promot Zakłady Metalowe
- Schmittergroup AG
- Thermolympic S.L.
- Vactron S.A
- Apinex
- Argus Fluidhandling LTD.
- Booster Precision Industrial
- BST Rods
- Cigüeñales Sanz
- Comercial de La Forja
- Dresser-Rand
- Industrias Ochoa
- Kendrion GmbH
- Industrias Cántabras Torneado (I.C.T.)

INDIRECT CUSTOMERS

**MANN+
HUMMEL**

- Cikautxo
- Edscha
- Freudenberg
- MMM Autoparts
- Montajes Abrera
- NSG Pilkington
- Pierburg



 **RENAULT**

JG AUTOMOTIVE

Your partner in metal solutions

customers

INDUSTRY

DIRECT CUSTOMERS

- AMPO
- Axolia Luxembourg
- CAF Signalling
- Diametal SAS France S.A.S.
- Expal
- Electrowatt France
- Grupo Klam
- Grupo Betico
- Hitachi
- Grupo Defontaine
- Hellstens Mecaniska AB
- Comexi
- Flex
- Rotrans
- MRO Defence S.L.
- Mondragon Group
- Ros Roca
- Rexnord Flaptop Europe
- Sedecal
- Thielmann Spain
- TSK Flagsol GmbH
- United Tech. (UTC)
- Wistra GmbH
- Vilisto GmbH
- Roquet
- Zitron S.A.
- Multi-Wing
- Araven

AGRICULTURE

DIRECT CUSTOMERS

- Bellota
- CBM S.p.A.
- Osmaq
- Capilla
- Sistemas Horticolas Almeria
- Tenias
- Agrimac

INDIRECT CUSTOMERS

- Columbia Gear Corporation

ELEVATION

DIRECT CUSTOMERS

- HIAB
 - HIAB Finland Oy
 - HIAB Poland SP Z.O.O
 - HIAB Sweden AB
 - HIAB Shanghai
 - DEL Equipment Ltd
 - HIAB Cranes S.L.
 - Waltco Lift Corporation
- Cemvisa Vicinay
- MP Componentes
- Stacke
- Wittur
- Zardoya Otis

WIND ENERGY

DIRECT CUSTOMERS

- Hine
- Vestas®
- Siemens Gamesa
- Glual

NAVAL

DIRECT CUSTOMERS

- Navantia
- MG Sanders
- Guascor Energy
- Irongrip

RAILWAY

DIRECT CUSTOMERS

- Stadler Valencia
- Vossloh España
- Barat Group
- Alstom
- CAF
- Refis

BUSES

DIRECT CUSTOMERS

- Hispacold
- Irizar
- Leciñena

MOTORCYCLES

DIRECT CUSTOMERS

- Gas Gas
- Sherco
- Rieju
- Torrot

HIGH-PRESSURE CYLINDERS

INDIRECT CUSTOMERS

- Drager Medical Hispania
- Linde Group
- Marioff Hi-Fog
- Praxair

JG AUTOMOTIVE

Your partner in metal solutions



Internacional presence



HEADQUARTERS

 Madrid

MANUFACTURING PLANTS

-  Barcelone
-  Vitoria-Gasteiz
-  Zaragoza

OFFICES

- | | |
|---|---|
|  Istanbul |  Ningbo |
|  Delhi |  Torino |
|  Chennai |  Barcelone |
|  Chongqing |  Lyon |

JG AUTOMOTIVE

Your partner in metal solutions

In **June 2002**, **JG Automotive** became a **Founding Partner** of the world's largest **global network of business development and engineering service providers**, establishing **Global Alliance Automotive**.

GLOBAL ALLIANCE AUTOMOTIVE

- **Active in the main automotive markets.**
- **19 independent local offices.**
- **15 countries** across **America, Europe, and Asia.**
- **€1.72 billion in revenue.**

GLOBAL REACH ALLIANCE

- **Full-service provider.**
- Global **network** of business development and engineering **service providers.**
- Access to **230 engineers** and **qualified specialists.**
- Stay alert to the latest **requirements, changes, and industry trends.**





JG AUTOMOTIVE

Your partner in metal solutions

Member of
Global Alliance
Automotive





JG AUTOMOTIVE

Your partner in metal solutions

sales

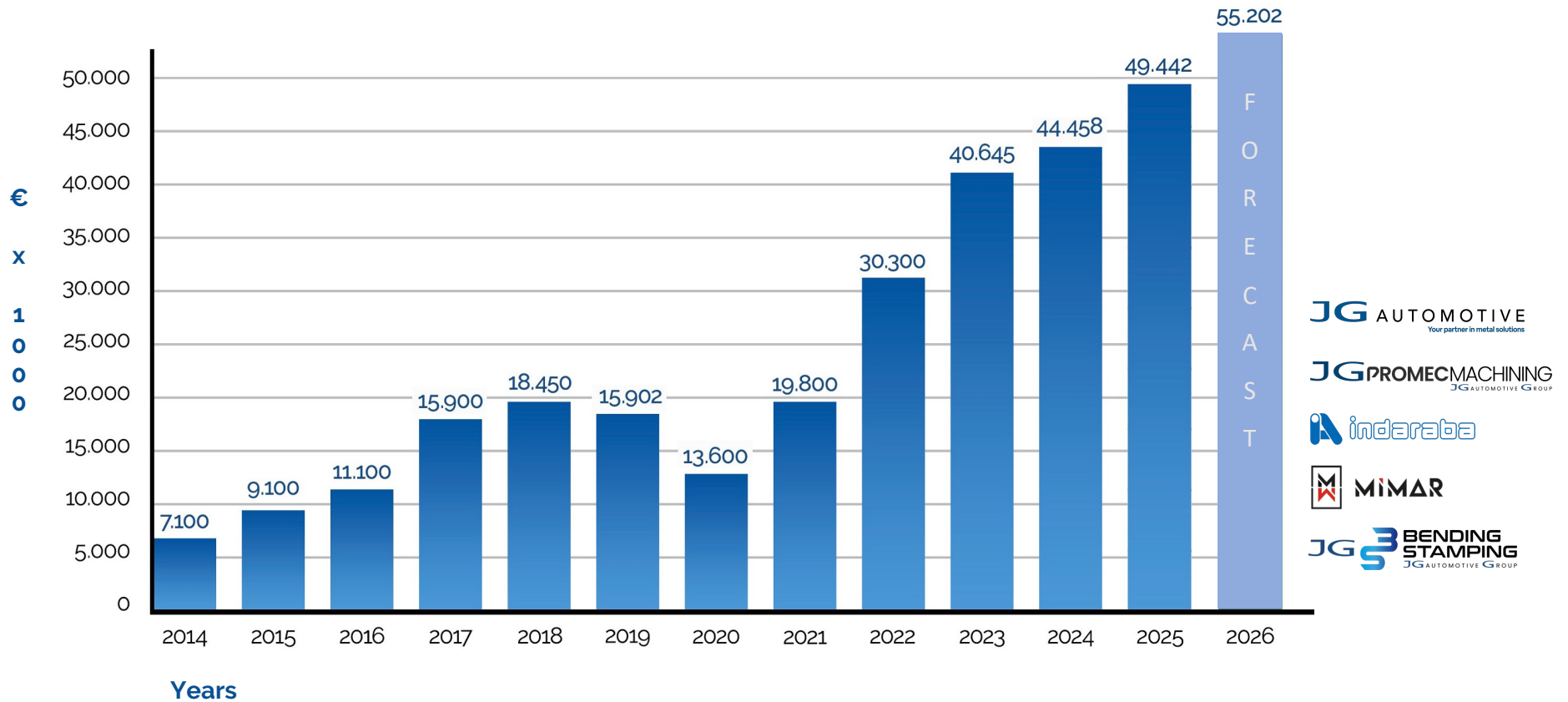

JG AUTOMOTIVE
Your partner in metal solutions

JG PROMEC MACHINING
JG AUTOMOTIVE GROUP

indaraba

MIMAR

JG 3 BENDING STAMPING
JG AUTOMOTIVE GROUP



INDUSTRIAL MACHINING

At **LASER MIMAR**, we operate advanced **machining centers**, including **5-axis CNC Haas machines**, which enable us to deliver high **precision** and **versatility**. This translates into solutions tailored for complex and highly demanding projects.

Our in-house machining capabilities make us **self-sufficient**, ensuring **flexibility** and **fast delivery** for every project. It also allows us to maintain **full control over quality** throughout the entire production process.

Backed by more than **150 clients**, we have strong **production capacity** to manufacture **industrial components**, as well as **CNC prototypes** and **custom-made parts**, ensuring the reliability of your **supply chains**.

We are your ideal manufacturing partner in **quality, price, and lead time**, from **prototype development** to **serial production**.



For more information:
lasermimar.com/mecanizado-industrial/



We operate equipment and machinery that enable us to provide a fully integrated service across a wide range of industrial machining techniques.

— LASER MIMAR





LASER CUTTING

At **LASER MIMAR**, we support companies and professionals with a fully **integrated service**, powered by the most advanced **technology**, ensuring the success of every project. Thanks to our extensive **high-quality material stock** and strong **production capacity**, we deliver a flawless **finish** within the agreed **lead time**.

Our **automated systems** allow us to cut from a single piece to large production volumes in very short times, with a **repetitive process** and maximum **precision** in every cut.

At **MIMAR**, we provide **industrial solutions** for all sectors, from small components for **automotive** or **railway**, to large-scale developments for **construction, infrastructure**, and **renewable energy**.

Materials:

- Carbon Steel
- Galvanized Steel
- Stainless Steel
- Aluminum
- Brass
- Copper

Finishes:

- Natural
- Vibrated
- Brushed with protective film
- Premium brushed
- Bright with protective film
- Premium bright

Thickness:

- From 0.5 mm to 25 mm in materials
- Mild Steel (AC) – AISI – Aluminum (AL)



For more information:
lasermimar.com/corte-laser/

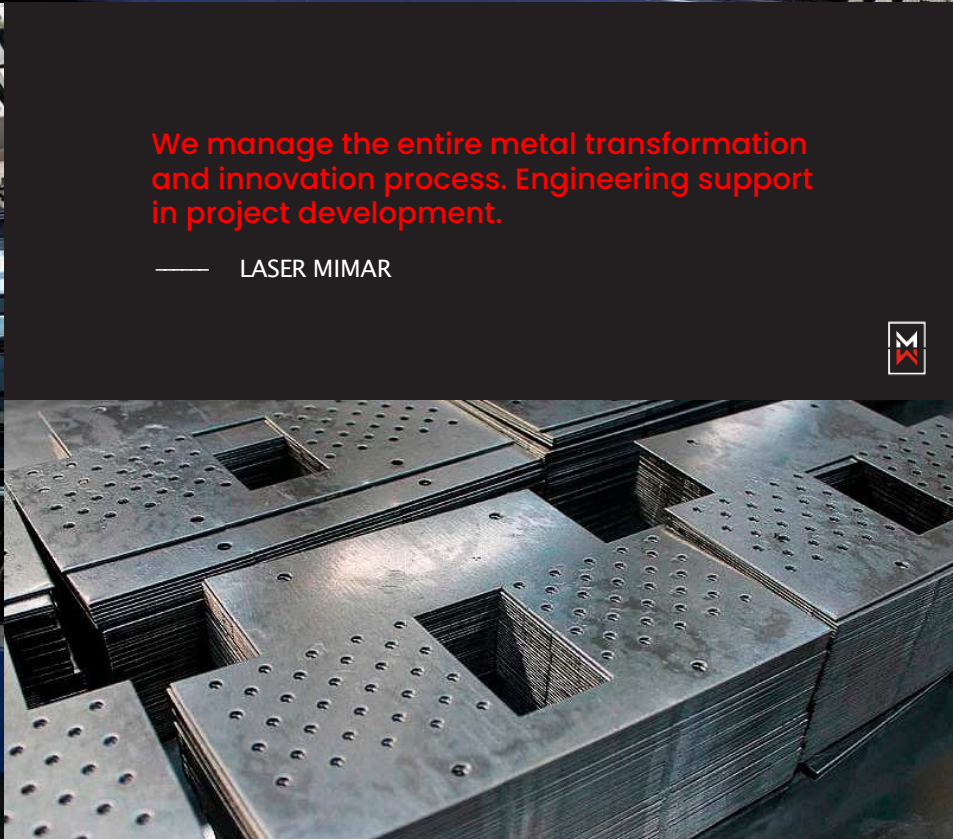

We manage the entire metal transformation and innovation process. Engineering support in project development.

— LASER MIMAR





BENDING

At **LASER MIMAR**, we operate state-of-the-art **automated bending equipment**, programmed by our **engineering team** to execute precise and fully **automated bending sequences**. This allows us to ensure **dimensional accuracy** and the desired **final geometry** of each part, while optimizing **cycle times** and guaranteeing **process stability**, a key factor in overall **product quality**.

We use advanced **CNC press brake machines** equipped with **automated tool storage systems**, enabling consistent **precision** and highly **efficient production processes**. In addition, our cutting department uses **automated systems** that generate the optimal **pre-form**, ensuring perfect **material positioning** from the very beginning.

Our **highly skilled team** brings the experience and specialization required in the **metalworking industry** to manufacture bent components with the highest **quality standards**, meeting the most demanding **market requirements**.



For more information:
lasermimar.com/plegado/

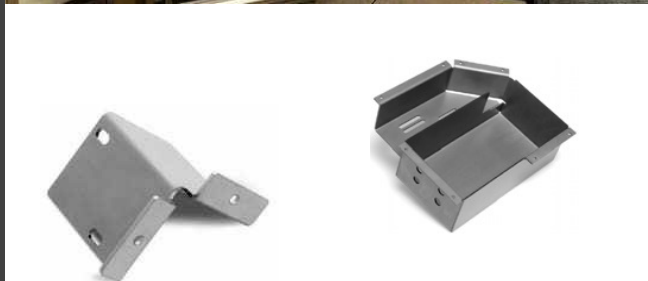

We precisely bend your metal parts,
whether simple or complex.

— LASER MIMAR





MECHANICAL ASSEMBLY AND INTEGRATION

At **LASER MIMAR**, we don't just manufacture individual components—we specialize in the **assembly of complex mechanical metal systems**. We offer the capability to integrate components such as **motors, mechanical actuators, electronic systems, displays, and fluid management solutions** into each structure.

We develop the full **engineering and design** of assemblies, transforming them into fully finished **machines**. A prior design from the client is not required: we have the internal capability to develop **end-to-end projects**, with the support of **JG Automotive engineers** when needed. Based on client requirements, we design and manufacture the final **functional system**, including all **technical documentation**.

Our capabilities in **design, metal forming, welding, machining, bonding, painting, and assembly** make us the ideal partner for **turnkey projects**, delivering fully completed **ready-to-use equipment**.



For more information:
lasermimar.com/montaje/



At LASER MIMAR, we deliver the best assembly and integration solutions, offering a fully integrated, high-quality, and completely customized service.

— LASER MIMAR

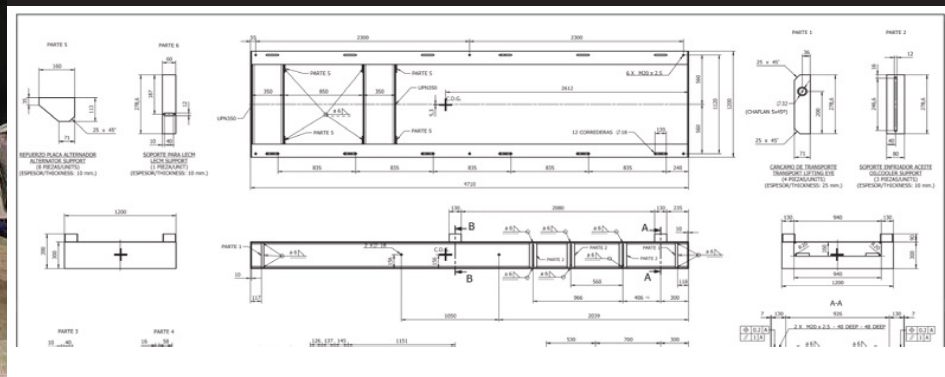



WELDING

At **LASER MIMAR**, we have a highly **qualified technical and human team**, capable of handling both **light and heavy manufacturing**, with strong expertise in **welded mechanical structures**.

We use **robotic automated welding**, ideal for **large production series** or projects with a high number of **welded joints**. This technology allows us to achieve greater **precision**, optimize **process efficiency**, and ensure more **competitive costs** in high-volume production.

In addition, we hold extensive **certifications and welding qualifications**, guaranteeing the highest **quality standards** required by our clients. We work with **TIG, MIG, and MAG processes**, applied to all types of materials such as **carbon steel, stainless steel**, and **aluminum**, from small components to large complete structures.

Our expertise in **aluminum** and **non-ferrous alloys** positions us as a **strategic partner** for highly demanding **industrial projects**.



For more information:
lasermimar.com/soldadura/



We have adapted to new technologies to offer the best welding services.

— LASER MIMAR





COLD WELDING

At **LASER MIMAR**, we have a highly qualified technical and human team capable of handling manufacturing projects ranging from **light-duty to heavy-duty**, with strong expertise in **cold welding**.

We hold extensive **certifications and approvals in cold welding**, allowing us to guarantee the required **quality standards** for each project.

Advantages of cold welding:

- **Safety:** Since it does not generate sparks or heat, it significantly reduces risks, especially in potentially **explosive atmospheres**.
- **Time:** It reduces downtime, as it is a **faster and more efficient process** compared to traditional welding.
- **Corrosion:** It avoids heat-affected zones, thereby reducing long-term **corrosion issues**.

Cold welding is an effective and highly recommended alternative for a wide range of **industrial applications**.



For more information:
lasermimar.com/soldadura-fria/

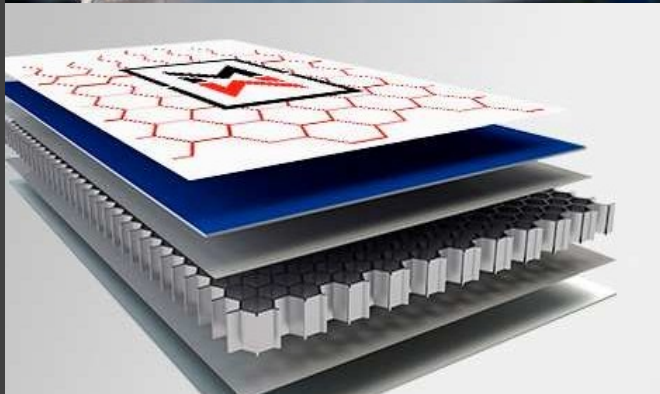

We have adapted to the new technologies available in the market to deliver the best results in Cold Welding.

— LASER MIMAR





PAINTING

At **LASER MIMAR**, we provide **tailored solutions** for industries that require highly demanding surface treatments. We operate our own **liquid painting facilities**, capable of meeting the strict standards of sectors such as the **railway and industrial industries**. We carefully control key parameters such as **paint thickness (microns)**, **metal adhesion**, **scratch resistance**, **color consistency**, and **corrosion protection**.

Our plant is equipped with **state-of-the-art technology** for liquid paint application, including both a **climate-controlled spray booth** and a **ventilated extraction area**. In addition, as part of the **JG Automotive Group**, we have access to advanced technologies that further enhance our capabilities.

The use of **liquid painting** allows us to achieve **uniform, fast, and high-quality finishes**, while also providing strong **production flexibility** to adapt to different volumes and optimize costs compared to other processes.

Our team has the **experience and specialization** required to guarantee **excellent finishes**, meeting the highest **quality standards** in every project.



For more information:
lasermimar.com/pinturas/



We offer our clients painting and finishing solutions with a fully integrated service.

— LASER MIMAR





MACHINERY

Our **metal forming machinery and systems division** delivers highly efficient **solutions and products**. With over **30 years of experience** in the **metalworking industry**, we specialize in **sheet metal fabrication** and **industrial boiler making**, covering the production of **metal parts and assemblies** through processes such as **cutting, stamping, bending, punching, assembly, and welding**. All of this is supported by the **technical expertise** of our team in **development, manufacturing, and process optimization**.

LASER MIMAR, together with the **JG Automotive Group**, provides **end-to-end manufacturing solutions**, powered by **state-of-the-art machinery**, ensuring **efficiency, quality, and competitiveness** in every project.



For more information:
lasermimar.com/maquinaria-lasermimar/



Automatic Sheet Metal Forming

MACHINE	BRAND	MODEL
Robotic Cell	TRUMPF	TruBend Cell 5000
Automatic Folding Machine	TRUMPF	TruBend Cell 5230
Automatic Folding Machine	LVD	Tool Cell 220/30 – 36665

Automated Laser Cutting

MACHINE	BRAND	MODEL
TruLaser 3040	TRUMPF	4,000 x 2,000 x 25 (Fiber)
TruStore 3040	TRUMPF	Series 3000

Robotic Welding

MACHINE	BRAND	MODEL
TRUMPF Robot	TRUMPF (Fronius 5000)	TruArc Weld 1000
MIG/MAG Welding Machine	Fronius	Transpuls Synergic 5000
KUKA	KUKA (Fronius 5000)	Robot with Track 7,000
+ 20 MIG/MAG/TIG Welding Equipment		

Marking

MACHINE	BRAND	MODEL
Continuous wave laser	TRUMPF	TRUMPF TruMark 1110



CNC Machining

MACHINE	BRAND	MODEL
HAAS UMC 500	HAAS	UMC 500 (5 axes)
HAAS VF-9	HAAS	VF-9 (3 AXLES)
HAAS VF-5	HAAS	VF-5 (3 AXLES)
(2x) HAAS VF-3	HAAS	VF-3 (3 AXLES)
HAAS ST-30 Lathe	HAAS	ST-30
BIGLIA CNC Lathe	BIGLIA	B-750 Y
BIGLIA CNC Lathe	BIGLIA	B-565 YS

Welding

MACHINE	BRANDS
+ 20 Automated Welding Equipment	<ul style="list-style-type: none"> ✓ Lincoln ✓ Lincoln Electric ✓ Lincoln Invertec ✓ Apasol ✓ CEA Compact ✓ Castolin Castotig ✓ Rehm-Apasol ✓ Fronius ✓ BTV GmbH. ✓ ATS

Paint

MACHINE	BRAND	MODEL
Paint Booth	LAUNCH	CCH4000 – 11 x 5 m.
Floor and Wall Vacuum	ASTRA	6,000 x 3,000
Sandblasting	LMM	VPI2XI STD-INOX
Sandblasting	LMM	SBF 10X8 INOX



MIMAR
products

PRODUCTS

In the **technical office** at LASER MIMAR, we develop—through **engineering processes**—all the products that are later manufactured in our plant, ensuring **full control from the initial stage**.

Thanks to our **automated systems** and our **specialized technical team**, we deliver **top-quality products**, guaranteeing **reliability and precision** in every project.

- > Machining
- > Machine Beds (Bases)
- > Welded Mechanical Assemblies
- > Low-Pressure Tanks
- > High-Pressure Tanks
- > Housings
- > Train Car Side Walls
- > Heat Exchangers
- > Filters and Valves
- > Assemblies



Product preparation for clients at the LASER MIMAR plant.



For more information:
lasermimar.com/productos/



We deliver top-quality products with the highest guarantee for our clients.

— LASER MIMAR





MIMAR
products

MACHINING

At MIMAR's **technical office**, we engineer all **machining products** that are later manufactured in our plant, ensuring **precision and full process control** from start to finish.

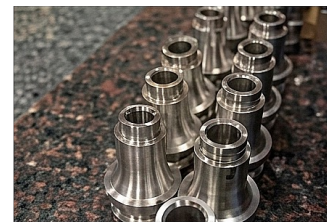

For more information:
lasermimar.com/productos-mecanizado/

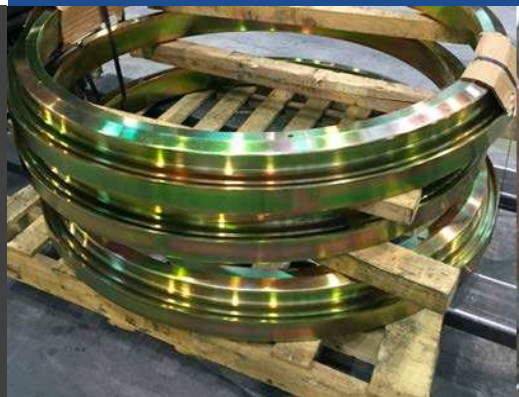



MIMAR
products

MACHINE BEDS (BASES)

At MIMAR's **technical office**, we engineer all **machine bed products** that are later manufactured in our plant, ensuring **precision and full process control** throughout the entire process.



For more information:
lasermimar.com/productos-bancadas/



WELDED MECHANICAL ASSEMBLIES

At MIMAR's **technical office**, we engineer all **welded mechanical assemblies** that are later produced in our plant, ensuring **precision and full process control** throughout the entire process.



For more information:
lasermimar.com/productos-conjuntos/



HOUSINGS (CASINGS)

At LASER MIMAR's **technical office**, we engineer all **metal housings** that are later manufactured in our plant, ensuring **precision and full process control** throughout the entire process.



For more information:
lasermimar.com/productos-carcasas/





MIMAR
products

ASSEMBLIES

At LASER MIMAR's **technical office**, we engineer all **industrial assemblies** that are later manufactured in our plant, ensuring **precision and full process control** throughout the entire process.



For more information:
lasermimar.com/productos-montajes/





MIMAR
products

FILTERS AND VALVES

At LASER MIMAR's **technical office**, we engineer all **filters and valves** that are later manufactured in our plant, ensuring **precision and full process control** throughout the entire process.



For more information:
lasermimar.com/productos-filtros-valvulas/





MIMAR
products

HIGH-PRESSURE VESSELS

At LASER MIMAR's **technical office**, we engineer all **high-pressure vessels** that are later manufactured in our plant, ensuring **precision, safety, and full process control** throughout the entire process.



For more information:
lasermimar.com/productos-depositos-alta-presion/



MIMAR JG **GROUP** **AUTOMOTIVE**
Your partner in metal solutions



LOW-PRESSURE VESSELS

At LASER MIMAR's **technical office**, we engineer all **low-pressure vessels** that are later manufactured in our plant, ensuring **precision, safety, and full process control** throughout the entire process.



For more information:
lasermimar.com/productos-depositos-baja-presion/



TRAIN CAR SIDE WALLS

At LASER MIMAR's **technical office**, we engineer all **train car side walls** that are later manufactured in our plant, ensuring **precision, strength, and full process control** throughout the entire process.



For more information:
lasermimar.com/productos-vagones-trenes/





MIMAR
products

PRODUCT VARIETY

At LASER MIMAR's **technical office**, we engineer a wide **variety of products** that are later manufactured in our plant, ensuring **precision and full process control** throughout the entire process.

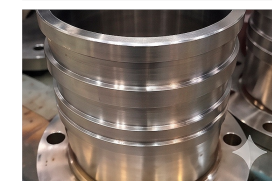
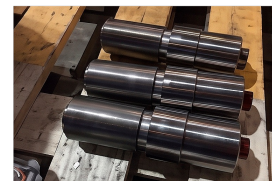
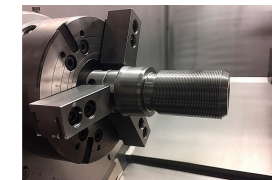

For more information:
lasermimar.com/productos-varios/





CERTIFICATIONS

To ensure a company-wide **quality-focused management system**, LÁSER MIMAR has obtained and applies the appropriate **certifications** aligned with its activity, always pursuing **continuous improvement** in both **product** and **process**.

ISO 9001:2015



EN 15085-2 CL1:2007



We hold **qualified welding procedures** in compliance with **ASME IX**, **ISO 9606**, and **ISO 15614** standards, guaranteeing the highest **quality** and **reliability** standards.



CORPORATE POLICIES

JG Automotive Group ensures accurate and up-to-date **documentation** at every stage of **development** and **production**, guaranteeing **smooth communication** and high **quality standards**.



Socially Responsible Investing



Responsible Minerals Policy



Responsabilidad Social Corporativa



MIMAR

JG AUTOMOTIVE
Your partner in metal solutions

JGA
Your partner in metal solutions



LASERMIMAR.COM

in /in/laser-mimar/

JG AUTOMOTIVE
Your partner in metal solutions



Av. de la Industria, 32D
28108, Alcobendas
Madrid

Carrer Diesel, 1, Pol. Ind. 1
08150 Parets del Vallès
Barcelona

+34 91 657 28 74

comercial@jgautomotive.com

JG AUTOMOTIVE ^{GROUP}
Your partner in metal solutions



JG PROMEC MACHINING
JG AUTOMOTIVE GROUP



JG ³ BENDING
STAMPING
JG AUTOMOTIVE GROUP