

JG **BENDING**
STAMPING
JG **AUTOMOTIVE** **GROUP**

Corporate Dossier

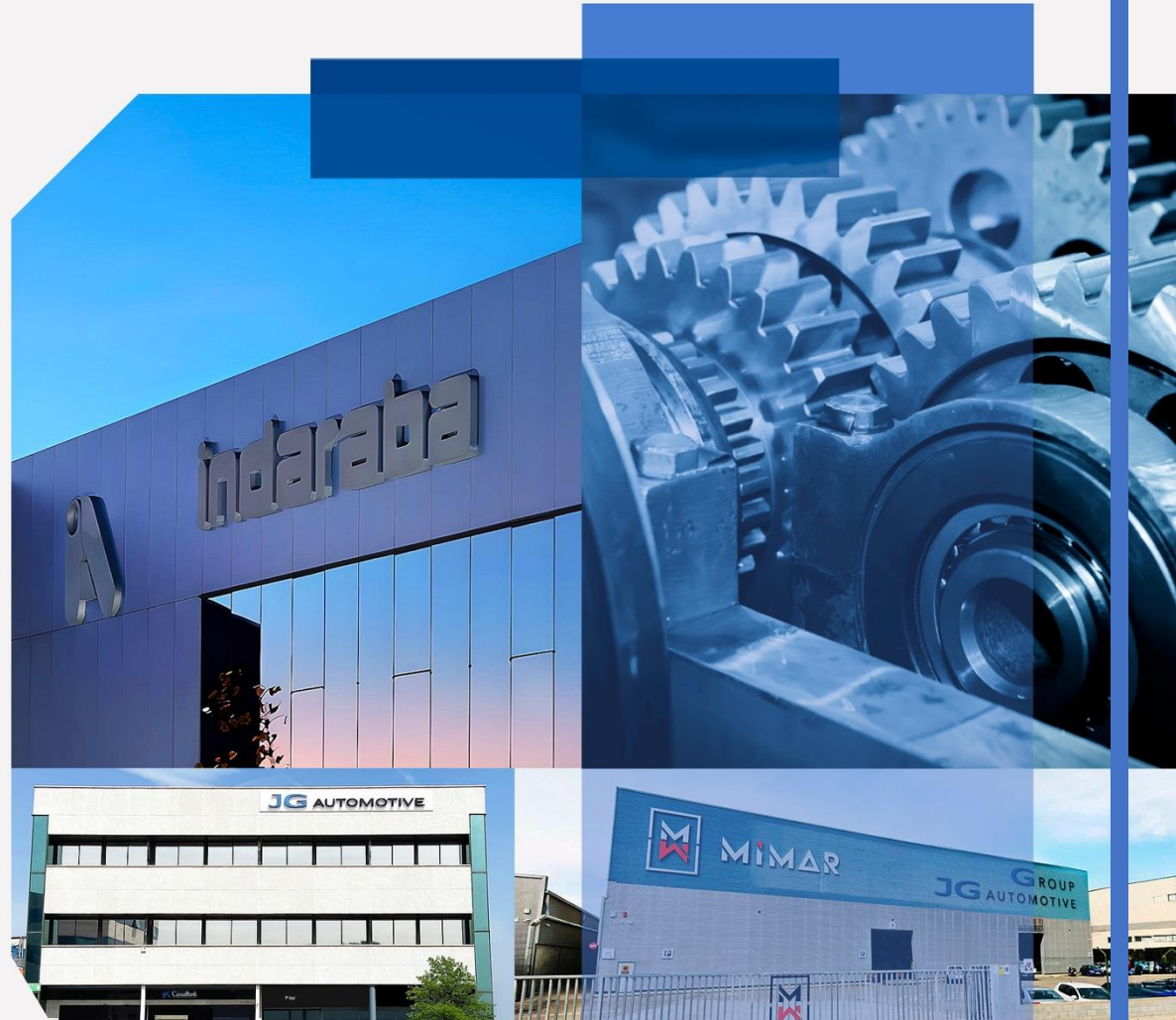

JG  BENDING
STAMPING
JG AUTOMOTIVE GROUP

JG  GROUP
AUTOMOTIVE
Your partner in metal solutions



ABOUT US

In November 2024, Talleres Grala adopted the name **JG Bending & Stamping**, joining the **JG Automotive Group** and consolidating our ability to deliver innovative and technologically advanced solutions on a global scale.

Since **1965**, we have been synonymous with quality and commitment in industrial manufacturing. Based in Zaragoza, we bring decades of experience, versatility in production processes, and a strong focus on customer adaptation. These strengths position us as a strategic partner in bringing manufacturing projects to life.

With more than **35 highly qualified professionals and a 4,000 m² facility**, we are fully prepared to provide comprehensive solutions. Our technical capabilities range from design to manufacturing and assembly of parts and components, employing stamping, bending, cutting, deep drawing, and welding processes.

Backed by **JG Automotive**, we reinforce our commitment to delivering value, quality, and reliability in every project, strengthening long-term trust with our clients.

JG AUTOMOTIVE

JG Automotive was founded in 1982, specializing in the manufacturing, development, and supply of metallic and mechanical components for the automotive and industrial sectors.

In 2002, together with 18 international partners, we established the **Global Alliance Automotive**, a group that brings together 230 engineers working in cooperation. Manufacturers from Brazil, Germany, China, India, Italy, Japan, South Korea, and the United States, among others, are part of this alliance, with a combined turnover of €1.72 billion.

JG Automotive stands as a benchmark supplier and manufacturer of custom-designed metal components for automotive and general industrial applications, using the most advanced technologies in forging, casting, machining, stamping, turning, and sintering. Mastery of these production technologies has enabled us to diversify our industrial sectors of operation and optimize our work processes.

JG AUTOMOTIVE

Your partner in metal solutions

customers

AUTOMOTION

DIRECT CLIENTS



- Baires (Buenos Aires)
- Bielefeld Unformtechnik Gmbh.
- Cerveira Lda.
- Esmar
- Global Tooling S.L.
- Puebla Sa De Cv
- Vendas Novas Unipessoal



- Goiaín
- Forjas Minas
- Gameko
- Mar Sk Ro
- Mecauto
- Nova Recid
- Recitec
- Zdanice
- Egaña



- Kober
- SAS
- Paderborn



- Polska
- SaDeCv



- ITW Mikalor
- ITW Global Fastener Spain
- ITW Shakeproof
- ITW Rivex



- ZF Friedrichshafen AG
- ZF Hungaária KFT
- ZF Boutheaon S.A.S
- ZF do Brasil
- ZF Kama



- Altan Plastik
- Aptiv
- Irfan Plastik
- OcakKalip



- Pontedera



- JD Germany
- JD USA
- JD Spain

INDIRECT CLIENTS



- Adient | Alagon
- Adient | Calatorap



- Kayaba Suspensions Europe



- Sekurit Spain
- Sekurit Portugal



JG AUTOMOTIVE

Your partner in metal solutions

customers

AUTOMOTION

DIRECT CUSTOMERS

• **APTIV** •

 **OFFICINE VICA**

Groupe
defta 

TRISTONE

DEUTZ®

- Grupo Riza
- ABC Plásticos
- Promot Zakłady Metalowe
- Schmittergroup AG
- Thermolympic S.L.
- Vactron S.A
- Apinex
- Argus Fluidhandling LTD.
- Booster Precision Industrial
- BST Rods
- Cigüeñales Sanz
- Comercial de La Forja
- Dresser-Rand
- Industrias Ochoa
- Kendrion GmbH
- Industrias Cántabras Torneado (I.C.T.)

INDIRECT CUSTOMERS

**MANN+
HUMMEL**

- Cikautxo
- Edscha
- Freudenberg
- MMM Autoparts
- Montajes Abrera
- NSG Pilkington
- Pierburg



 **RENAULT**

JG AUTOMOTIVE

Your partner in metal solutions

customers

INDUSTRY

DIRECT CUSTOMERS

- AMPO
- Axolia Luxembourg
- CAF Signalling
- Diametal SAS France S.A.S.
- Expal
- Electrowatt France
- Grupo Klam
- Grupo Betico
- Hitachi
- Grupo Defontaine
- Hellstens Mecaniska AB
- Comexi
- Flex
- Rotrans
- MRO Defence S.L.
- Mondragon Group
- Ros Roca
- Rexnord Flaptop Europe
- Sedecal
- Thielmann Spain
- TSK Flagsol GmbH
- United Tech. (UTC)
- Wistra GmbH
- Vilisto GmbH
- Roquet
- Zitron S.A.
- Multi-Wing
- Araven

AGRICULTURE

DIRECT CUSTOMERS

- Bellota
- CBM S.p.A.
- Osmag
- Capilla
- Sistemas Horticolas Almeria
- Tenias
- Agrimac

INDIRECT CUSTOMERS

- Columbia Gear Corporation

ELEVATION

DIRECT CUSTOMERS

- HIAB
 - HIAB Finland Oy
 - HIAB Poland SP.Z.O.O
 - HIAB Sweden AB
 - HIAB Shanghai
 - DEL Equipment Ltd
 - HIAB Cranes S.L.
 - Waltco Lift Corporation
- Cemvisa Vicinay
- MP Componentes
- Stacke
- Wittur
- Zardoya Otis

WIND ENERGY

DIRECT CUSTOMERS

- Hine
- Vestas®
- Siemens Gamesa
- Glual

NAVAL

DIRECT CUSTOMERS

- Navantia
- MG Sanders
- Guascor Energy
- Irongrip

RAILWAY

DIRECT CUSTOMERS

- Stadler Valencia
- Vossloh España
- Barat Group
- Alstom
- CAF
- Refis

BUSES

DIRECT CUSTOMERS

- Hispacold
- Irizar
- Leciñena

MOTORCYCLES

DIRECT CUSTOMERS

- Gas Gas
- Sherco
- Rieju
- Torrot

HIGH-PRESSURE CYLINDERS

INDIRECT CUSTOMERS

- Drager Medical Hispania
- Linde Group
- Marioff Hi-Fog
- Praxair

JG AUTOMOTIVE

Your partner in metal solutions



International presence



HEADQUARTER

 Madrid

FACTORIES

-  Barcelone (x2)
-  Vitoria-Gasteiz
-  Saragossa

OFFICES

- | | |
|--|---|
|  Istanbul |  Ningbo |
|  Delhi |  Torino |
|  Chennai |  Barcelone |
|  Chongquing |  Lyon |

JG AUTOMOTIVE

Your partner in metal solutions

sales

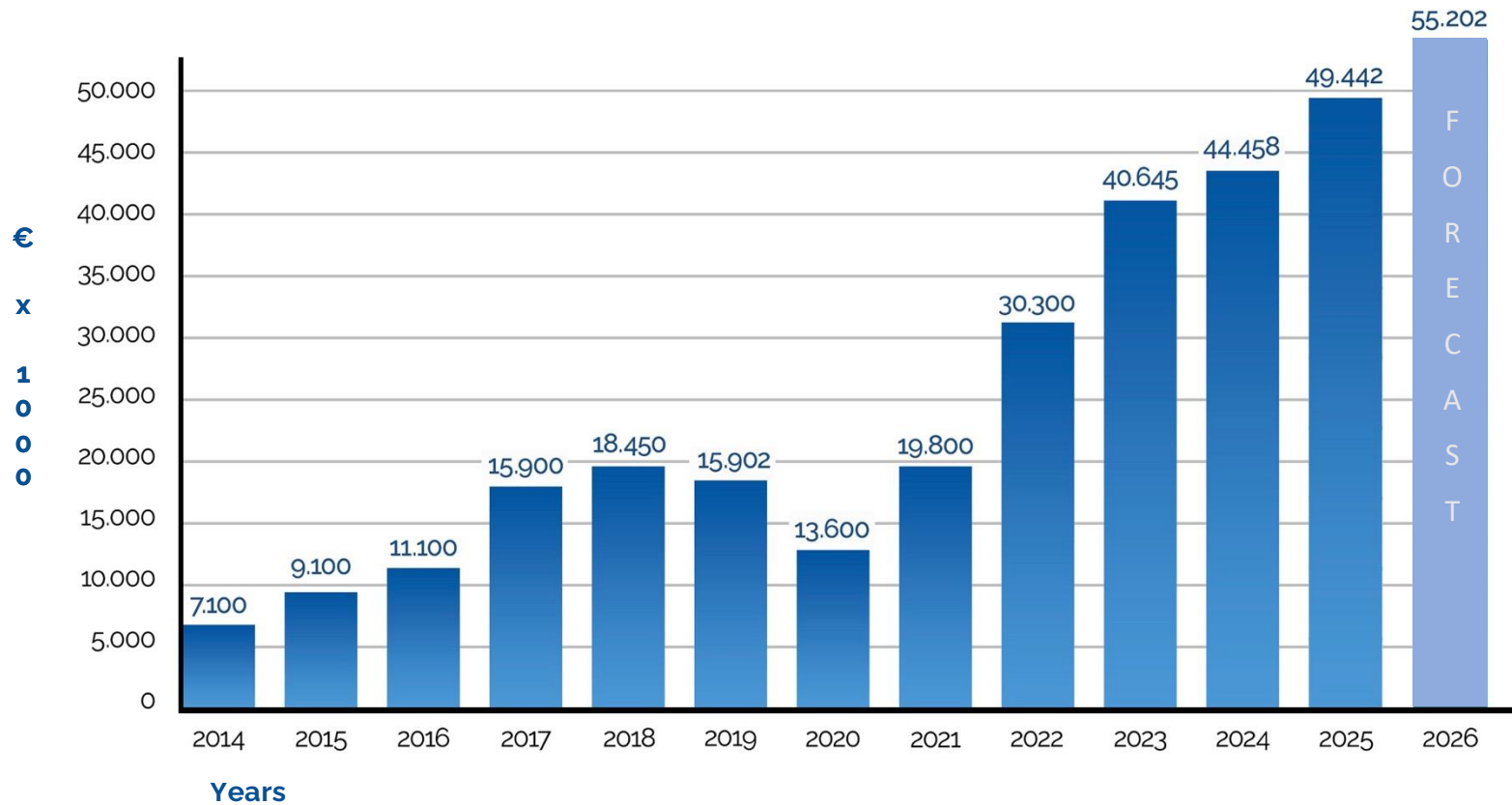

- JG AUTOMOTIVE**
Your partner in metal solutions
- JG PROMEC MACHINING**
JG AUTOMOTIVE GROUP
- indaraba**
- MIMAR**
- JG BENDING STAMPING**
JG AUTOMOTIVE GROUP

STAMPING

Work with eccentric presses from 400 to 5,000 KN. Deep drawing, cutting, and stamping processes up to 8 mm thickness and 500 mm strip width.

Presses with Feeder

- **Esna 100 Tm.** Gripper feeder, up to 250 mm feed length. Feeder capacity: up to 250 mm strip width and 3 mm thickness.
- **Esna 160 Tm.** Roller feeder, up to 600 mm feed length. Feeder capacity: from 40 to 300 mm strip width, with thicknesses from 0.5 mm to 4 mm.
- **Arisa 500 Tm.** Roller feeder, no limit on feed length. Feeder capacity: up to 500 mm strip width and 8 mm thickness.

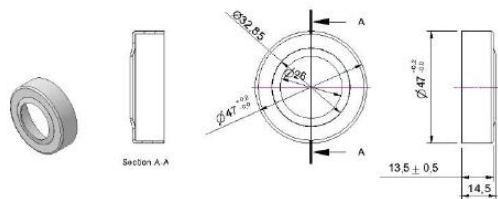

Presses without Feeder

- Esna 40 Tm
- Esna 45 Tm
- Esna 80 Tm
- Aitor 250 Tm
- Esna 315 Tm

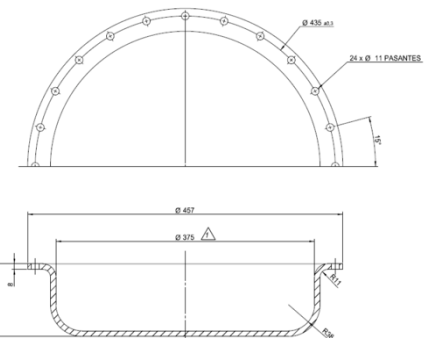

Deep-drawn sheet metal part in 8 mm thickness for industrial valves.

TUBE CUTTING

We have **Adige CNC machines** with automatic feeding for **tube and bar cutting** (65 mm – 3000 mm), as well as two semi-automatic saws, one small band saw, one swing-frame saw, and one manual saw.

Cutting capacity depends on the tube shape:

- **Round tube:** up to 102 mm diameter.
- **Square tube:** up to 80 mm side.
- **Rectangular tube:** up to 100 × 60 mm.

The maximum cutting length for the automatic saw is 3 m, and the maximum bar length to be processed is 6 m.

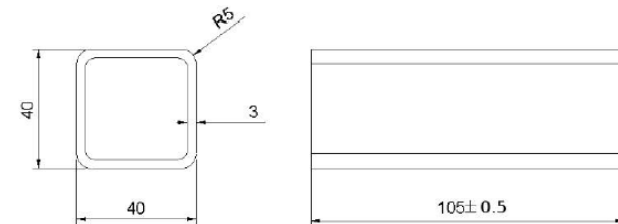
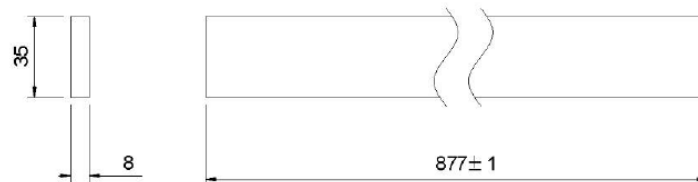
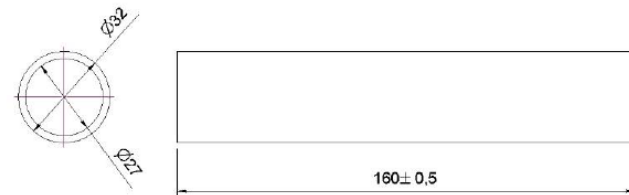

TUBE BENDING

Tube bending is a cold-forming process applied to metal tubes. We have three bending machines: two multi-radius machines for tubes up to 65 mm outer diameter, and an additional one for tubes up to 42 mm.

- **Macri 45 Bender:** 6-axis machine, up to 45 mm outer diameter.
- **Macri 65 Bender:** 6-axis machine, up to 65 mm outer diameter.
- **Tejero Bender:** H42 CNC.

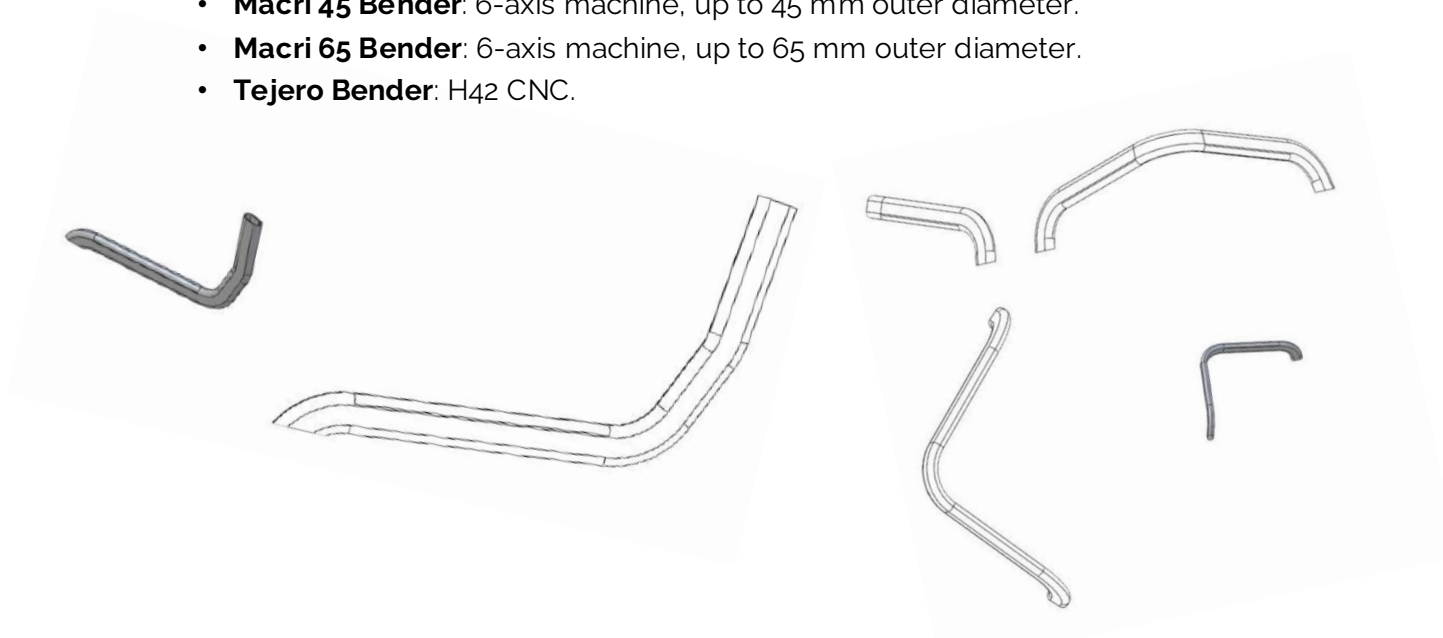

MIG/MAG WELDING

5 MIG/MAG welding robots.
Manual MIG/MAG welding available.

- Part for trundle bed, cut in press and welded.
- Component assemblies for electric beds.
- Shopping cart structure.



MACHINING

- **CNC Machining**
 - Vertical CNC machining center
 - HASS VF4
 - CAM software 2.5 axes
- **Manual Machining**
 - Prototype lathe
 - Column drill
 - Axial grinder



LASER CUTTING AND BENDING

With our extensive stamping experience, we offer the option of combining **laser cutting with press bending**. For long production runs, using the press is often faster and more cost-effective than a folding machine.

We provide high-quality flat laser cutting services for carbon steel, stainless steel, and galvanized steel. By optimizing sheet utilization, we ensure efficient and precise results for both short and large series.

AMADA LCG-3015 LASER

- **Maximum sheet dimensions:** 3000 x 1500 mm.
- **Maximum thickness:**
 - Carbon Steel 20 mm.
 - Stainless steel: 10 mm.
 - Galvanized steel: 3 mm.

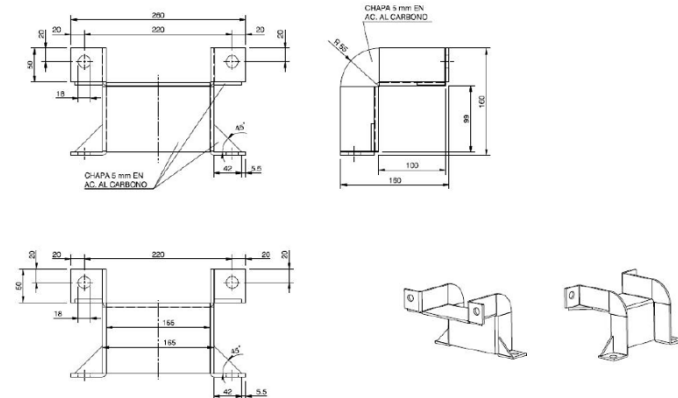

AMADA HFE-M2 100 T Press Brake

- **Maximum bending length:** 3000 mm.

TUBE CUTTING



TUBE BENDING

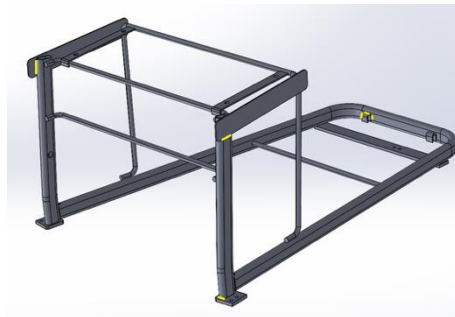
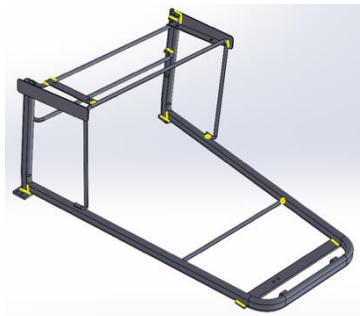

JG **BENDING STAMPING**

JG AUTOMOTIVE GROUP
products

STAMPING

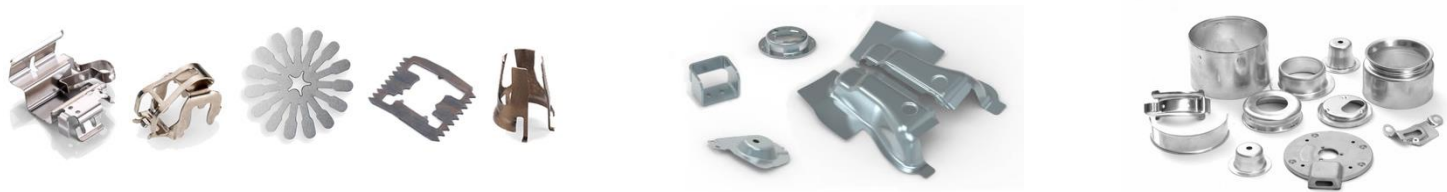

MIG/MAG WELDING

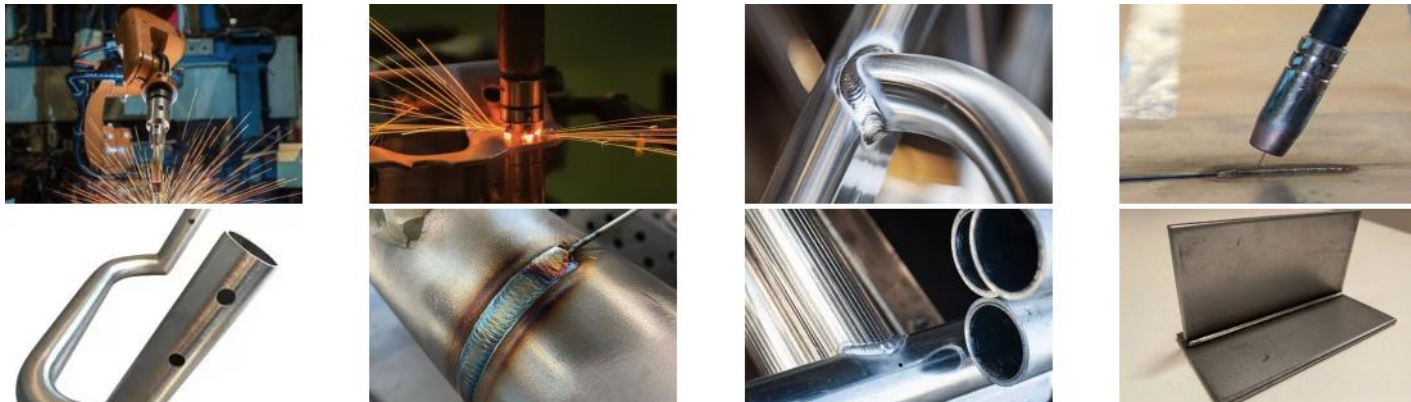

ASSEMBLIES



FACILITIES



JG BENDING STAMPING

JG AUTOMOTIVE GROUP
machinery

FACILITIES



JG BENDING STAMPING

JG AUTOMOTIVE GROUP
machinery

FACILITIES



CERTIFICATIONS

To ensure a **quality-focused** business management system **JG Bending & Stamping** has obtained and applies the certification appropriate to its activity, always striving to maintain continuous improvement of both product and process.

IATF 16949:2016



Scheduled for Q1 2026

ISO 9001:2015





CORPORATE POLICIES

JG Automotive Group ensures accurate and up-to-date documentation at all stages of development and production, guaranteeing smooth communication and high-quality standards.



Socially Responsible Investing



Responsible Minerals Policy



Corporate Social Responsibility



"PAIP" Program: Support for Industry and SMEs in Aragón

This company participates in the "PAIP" Program, which aims to promote the growth and consolidation of SMEs by improving their financing, technology, and access to advanced support services.

Objective of the operation: To achieve a more competitive business environment.

Operation co-financed by the European Union

**Operational Program – European Regional
Development Fund Aragón 2014-2020**

Building Europe from Aragón

JG  BENDING
STAMPING
JG AUTOMOTIVE GROUP

JG  GROUP
AUTOMOTIVE
Your partner in metal solutions



JGBENDINGSTAMPING.COM

in /in/jgautomotive

JG AUTOMOTIVE
Your partner in metal solutions

Av. de la Industria, 32D
28108, Alcobendas
Madrid

JG 3 BENDING STAMPING
JG AUTOMOTIVE GROUP

C. Río Huerva, Naves 24-25-26
50410, Cuarte de Huerva,
Zaragoza

+34 91 657 28 74

comercial@jgautomotive.com

JG AUTOMOTIVE GROUP
Your partner in metal solutions



JG PROMEC MACHINING
JG AUTOMOTIVE GROUP



JG 3 BENDING STAMPING
JG AUTOMOTIVE GROUP